

# homeward**b**ath

## Installation and Operation Manual

### **MG-304**



Please read this manual carefully before use.

## Important Safety Instructions:



- Use this unit only for its intended purposes or as described in this manual. Use only attachments recommended by the manufacturer.
- Risk of hyperthermia and possible drawing. Water temperature in excess of 38°C may be injurious to your health. Check and adjust temperature before use.

## Read and Follow all Instructions

- Danger: To reduce the risk of injury, do not permit children or persons with infirmities to use this product unless they are closely supervised at all times.
- To avoid injury, exercise care when entering or exiting the walk-in tub.
- Never drop or insert any objects into any openings.
- Risk of electrical shock; connected only to a separate circuit protected by a ground fault circuit interrupter (GFCI).
- Warning: Risk of electric shock; do not permit electric appliances (such as a hair dryer, lamp, telephone, radio, or television) within 1.5M of this hydro-massage bathtub.
- The unit must be connected to a circuit interrupter (GFCI). Such a circuit is provided by the installer and should be tested on a routine basis. To test the GFCI push the test button; the GFCI should interrupt power. Push the RESET button; power should be restored. If the GFCI fails to operate in this manner, there is a ground current flowing, indicating the possibility on an electrical shock. Do not use this unit. Disconnect the unit and have the problem corrected by a qualified services representative before using.
- Traction enhanced-textured tub bottom must remain clean to minimize slippage.
- Risk of electrical shock; all pumps must be connected to a ground fault circuit interrupter (GFCI) protected outlets.
- Avoid use of alcohol, drugs, or medication while using your walk-in tub.
- Consult your physician before using the whirlpool/air system if you are pregnant and/or have heart conditions.
- All units must be water tested before installation.

## Unpacking the Unit

1. Inspect the carton, if carton damage is noted: take a picture if possible, notify the deliverer.
2. NEVER LIFT THE TUB BY THE PLUMBING. Doing so can result in leaks, for which the installer is responsible.
3. Immediately inspect the unit for damage even if there is no carton damage. Once the unit is installed surface damages will be assumed to be installation related if not reported at this point. Installers are responsible for damage that occurs once the unit is placed in its niche.
4. Inspect the plumbing for any loose fittings.
5. Remove all packaging material except for the protective plastic. This has been placed on the tub at the factory to eliminate abrasions from handling. This should only be removed at final clean up.

## Testing Your Tub before Installation

1. All Tubs are 100% water tested at the factory and certified to be free of leaks. Transportation and mishandling may cause leaks. It is necessary to test the bath while there is access to all sides of the bath.
2. This unit should be both static and operationally tested with water. It is best to test the unit outside by filling with a garden hose.

**Note:** Install all hardware on a soaking tub, prior to testing

- a. Place the tub on a completely flat surface in an area where it may be drained after testing.
- b. Seal the drain (can be sealed with tape for test) and fill the tub three inches about the jets or to a normal level if it's a soaking tub.
- c. Allow the water to stand in tub for 10 minutes and then inspect all plumbing and seals for leaks.
- d. Using an extension cord, operate each pump (air and hydro system if applicable) for 10 minutes and inspect for leaks. Inspect the unions around the pump; if leaks persist from the units after tightening; loosen the unions and insure that the O-ring is seated properly.
- e. Insure all jets are open and working (every hydro jet is adjustable for both flow rate and direction of flow, depending on the jet, the water flow is adjustable by either turning the outside ring or the nozzle clockwise and counter clockwise).

Note: If the pumps do not operate:

- a. Check the breaker to insure power is on and the cable connecting the controls to the pump is attached
- b. If an optional heater is present, check the indicator light on the heater to insure that power is present.

Do not run any pumps or heaters unless the tub is filled with water to proper level. Damage due to dry running pumps is not covered under 3 year warranty.

Failure to perform these tests before installation will make the installer liable for future repair costs.

## NOTICE TO INSTALLERS

THE FLEXIBLE DRAIN HOSE THAT IS INCLUDED WITH THIS UNIT IS FOR INSTALLATION INTO AN OPEN FLOOR DRAIN ONLY. SUBSTITUTING THE EXISTING DRAIN SHOE FOR A DIFFERENT ONE WILL NOT VOID THE WARRANTY AS LONG AS THERE NO DAMAGE OR EVIDENCE OF MISUSE TO THE BASE

## FEATURES

- ❖ Waterproof 15 ½" Walk-in Door
- ❖ Thermostatic Water Valve
- ❖ Inward Swinging Door
- ❖ Polished Finish
- ❖ Safety Grab Bar
- ❖ Tub filler
- ❖ Hand-held Shower
- ❖ Molded Seat – 17" High & 25" Wide
- ❖ Luxurious Head Rest Pillow
- ❖ Dual drain system
- ❖ Left and Right hand drains available
- ❖ Easy Installation (4-6 Hrs)
- ❖ Limited Life Time Warranty on the Door Seal

Left Hand Unit

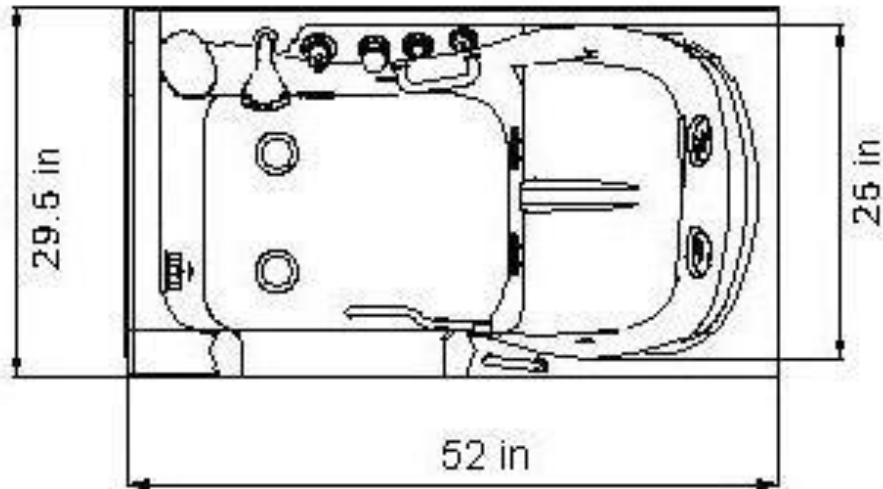
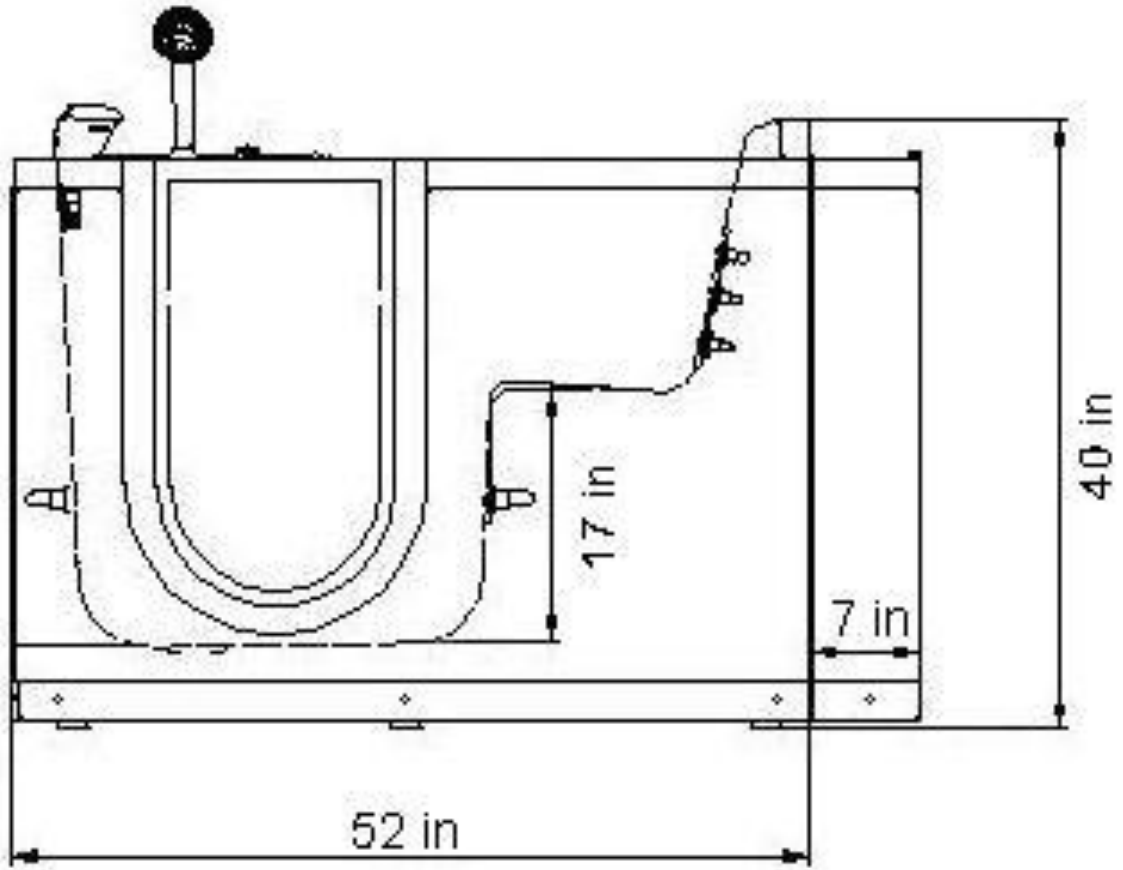

Right Hand Unit

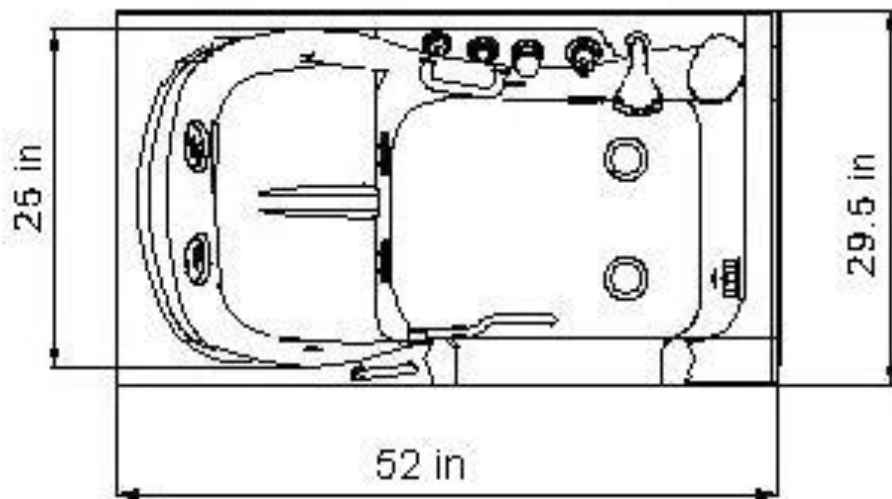
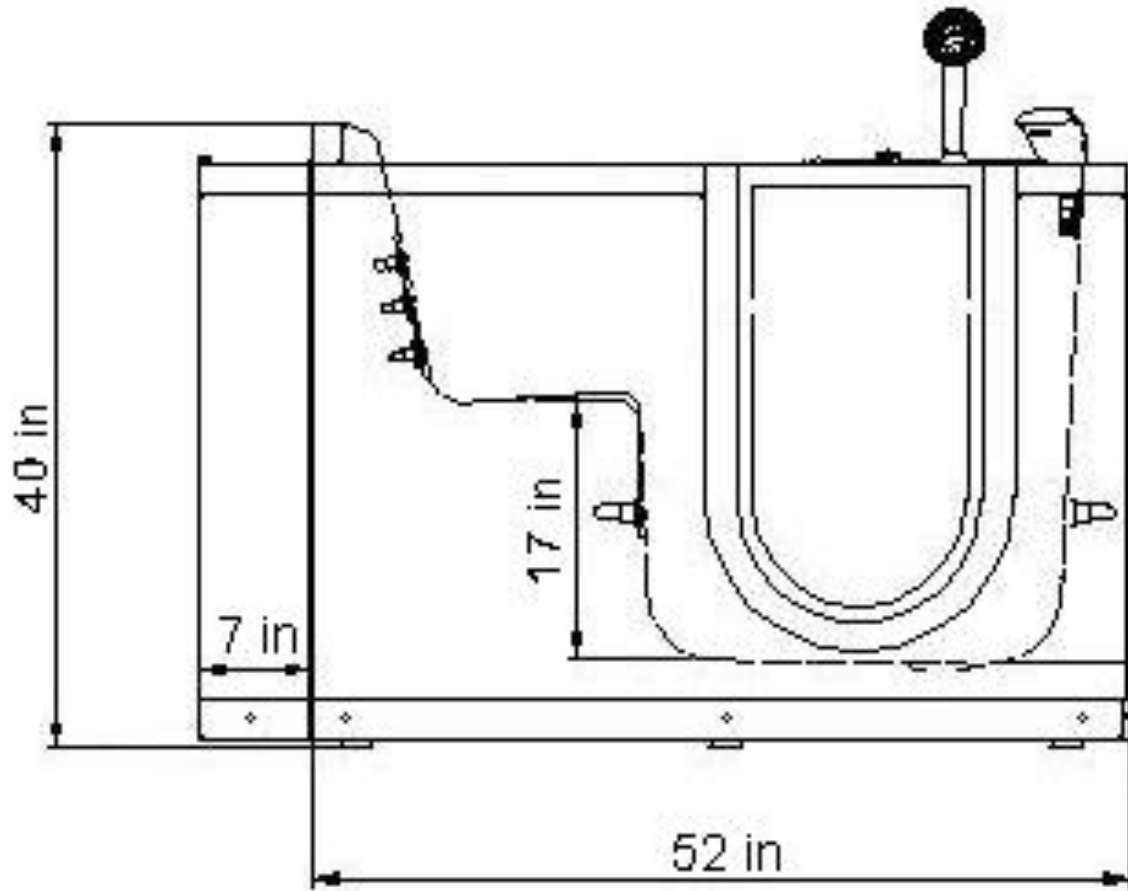

## **Installation Preparation**

1. Check the floor area where the tub is to be installed
  - a. Clean area of any debris or trash
  - b. Use a 5 or 6-foot level and determine if the floor is leveled. If the floor is not leveled, adjust all leveling feet to perfectly level the tub. Note: it is important that all leveling feet are completely touching the floor and level for the door system to work properly.
2. Check to insure that the drain has been placed at the proper location. See spec sheets attached to your unit.
3. Insure that the proper electrical service has been installed at the pump location. See electrical requirements below.

## **TECHNICAL SPECIFICATIONS**

### **AVAILABLE IN FOUR VERSIONS:**

- M-G304 – plain soaking tub
- M-G304A – 24 heated air jets
- M-G304W – 14 heated water jets
- M-G304WA – 14 heated water and 12 heated air jets system

### **TECHNICAL INFORMATION**

- **Materials:** Acrylic Composite
- **Power Supply:** 110V, 2.25KW
- **Dimensions:** 52 x 29.5 x 40 IN (59in. with extension panel)
- **Water Usage:** 50-60 Gallons
- **Drain capacity:** 40 gallons per minute

### **PLUMBING REQUIREMENTS**

- Unit is equipped with flexible, metal braided ½ inch water supply hose with ½ female threaded connectors
- Need to install hot and cold shutoffs with ½ male threaded nipples (not included)

**Note:** The flexible drain hose that is included with this unit is for installation into a floor drain only. Substituting the existing drain show for a different one will not void the warranty as long as there is no damage or evidence of misuse.

### **ELECTRICAL INFORMATION**

- **M-G304A** –Heated Air Jet Motor 110v 8A  
(*Dedicated line 12-2 wire with 110 volt, 15 amp GFCI breaker* )
- **M-G304W** – Heated Water pump 110-120V 9.4A  
(*Dedicated line 12-2 wire with 110 volt, 15 amp GFCI breaker* )
- **M-G304WA** – Heated Water pump 110-120V 8A, Air jet motor with heater 110 volt 8A  
(*Dedicated line 12-2 wire with 110 volt, 20 amp GFCI breaker* )

### **MG 304 W (water jets)**

The MG 304W (water jets) requires dedicated 15amp GFCI protection with 12-2 wiring. The water pump is connected to a junction box under the tub. The installer needs to run the appropriate power cord from the power supply to the junction box. A certified wall plug or hard wiring can be used. All equipment must comply with local electrical codes.

### **MG 304 A (heated air)**

The MG 304A (heated air) requires- 15 amp GFCI protection with 12-2 wiring. The Air pump comes with a NEMA plug (three prong plug) to be plugged in to a GFCI protected outlet.

### **The MG 304 WA (water jetted, inline heater and hot air)**

The MG 304 WA (heated water & hot air jets). The unit requires dedicated 20 amp GFCI protection. The separate heated air pump will also require a connection as described above for the MG 304A. The heated whirlpool pump will require the MG304W described connection.

**\*\*All electrical connections must be carried out by a certified electrician in accordance with local electrical requirements and codes.**

### **GENERAL INFORMATION**

**Note:** It is advised to have the tub onsite before preparing drain location. Please call with any questions regarding drain hookup.

Unit must be leveled in its permanent position and all feet must be on the ground to fully support the tub.

**Please check fittings for tightness before final connections.** Connections may have loosened during shipping. ***Manufacturer reserves the right to change specs or features at anytime. Please check to confirm details. 1-866-783-2661***



**Installation of Fixtures for Soaking Tub (only):**

**Note:** Images are for Right Hand Unit. Order will be reversed for a Left Hand unit.

Connect the hose:



From

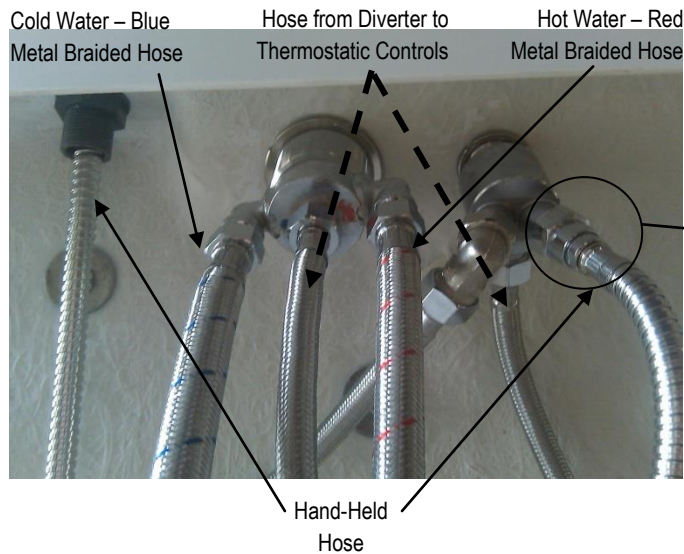

**Note:** the nut on the hose needs to be undone to feed thru the Hand-Held hole in Tub

To



Final Result

## Installation of Extension Panels:

**Note:** Images are for Right Hand Unit. Order will be reversed for a Left Hand unit.

Attaching the top panel to tub:



Attaching bottom brackets:



Attaching top brackets:



Attaching Side Panel to Skirt:



## Installation Procedures:

Warning: When installing jet massage baths, air massage baths, or dual baths, basic precautions should be followed, including:

- Danger: Risk of electrical shock. Connect only to a separate circuit protected by a ground fault circuit interrupter (GFCI)
  - Installation must provide access for servicing pump/motor (all tubs come with an access panel for the pump/motor and faucet).
1. Install tub waste/overflow according to instructions provided with fitting.
  2. Install faucet. If spout and supply lines are to be installed on deck of tub, mark the locations and drill pilot holes from acrylic side of product.

Note: It is best to position the diverter directly over the overflow for easy installation. The sequence would be: handle, handle, diverter, spout and then handheld.

3. Standard installation – After framing is complete (see attached diagrams), set product in place to check fit and make certain that the tub can be properly leveled. (Caution: if walk-in bathtub is not resting on all five leveling feet, water will not drain properly and may cause the door to leak).
4. Verify the product is completely level by checking tub deck surface and ensure all 5 leveling feet are touching the ground.
5. Electrical connection is made by simply plugging pump cord (shipped with cord and plug) into specified dedicated 120V, 30A, GFCI outlet.
6. After plumbing and electrical connections have been made the tub should be cleaned of dirt and debris.
7. Installation is not complete until the bath has been water tested in place.

## Operating Instructions:

1. Enter the Walk-in Tub, close the door and fill the bath at least 3 inches below the overflow before activating the pump.
2. The pump will be activated by the on/off control. Each depression of the button changes cycles. Do not repeatedly/rapidly press the switch. It may take a few seconds before an energized system is visible.
3. Adjust the direction and rate of flow for each jet to your liking by moving the nozzle for direction and turning either the outside right or the nozzle clockwise or counter-clockwise for flow (some jets adjust the flow with the outside ring and some with the nozzle).
4. If your Walk-in Tub is equipped with a heater, the heating element will automatically turn on when the whirlpool is turned on. The heater is designed to maintain the water temperature longer.
5. If any factory installed fittings are removed, do not operate the unit. A safety hazard may be present.
6. Do not use bubble bath when any pumps are operating.
7. Bath oils may be used; however their frequent use will require more frequent cleaning of the systems.
8. Both air and whirlpool systems are plumbed so that water will drain from the plumbing after each use.
9. There are no user serviceable parts located under the tub.

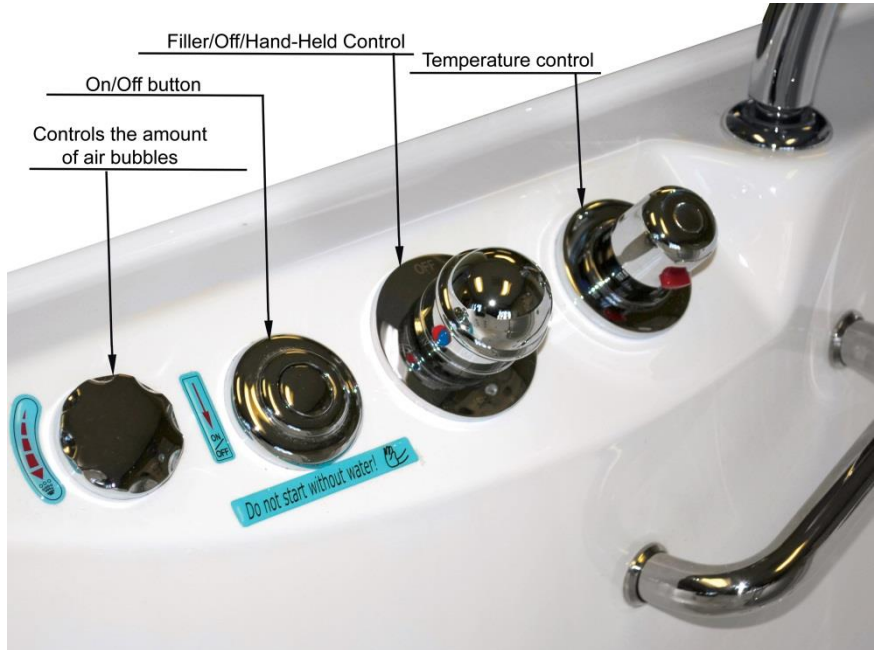

Note: Do Not open the Walk-In Tub door while water is still in the tub.

## Heated Air Pump

The heated air pump has two speeds. When started, the pump will run from 20 to 30 minutes before shutting off on its own. The pump can be immediately restarted if more time is desired by pressing the on/off button. After the air pump has been off for 30 minutes the air pump will automatically start up again, it will run on low speed for about 5 minutes then automatically go to the high speed for about 15 minutes. This is normal. The unit is blowing out any water in the system and drying the airline system.

If you press the on/off button the cycle will repeat itself!

## In-Line Heaters

If your bath is equipped with an optional in-line heater it will operate only when the pump is on. It is always on when the whirlpool pump is on. Note: the in-line heater is designed to keep your water warm longer but is not designed to increase the water temperature. Heat settings are not adjustable.

**Troubleshooting:**

Phenomenon	Reason	Solution
Pump doesn't work	1. Power plug is not plugged in all the way 2. Residual Current Protective device is off	1. Make sure the power is plugged in all the way. 2. Find & remove short circuit, then connect the protection switch.
	Impeller of pump is stopped by sundries	Clean the impeller
	Didn't switch on the pump	Turn the pump on
	Pump is broken	Change the pump
	Poor connection between the air pipe and air switch	Reconnect both parts
	No power	Check the wiring
Water Jet strength is not adjusting	Abnormal voltage	Check the voltage and use adapted transformer
	Air is not switched on	Check or charge the air switch
	Suctions stopped	Clean suction
Massage bathtub is not leveled	Leveling feet are not adjusted	Adjust the leveling feet
Water pipe leaks	Poor seal ring	Reinstall or change seal ring
	Nut is connected poorly	Tighten the nut
	Poor joint connection	Reconnect and silicon on

\*If there are other questions, please call Technical Support at 866-783-2661

## **Cleaning and Maintenance:**

Pump and pipe circulation system should be flushed before first use and on a monthly basis when product is under normal use. Below are the recommended procedures for cleaning:

- Do not run whirlpool dry. Fill the tub with hot water 2-3 inches above the jets and add 2-3 teaspoons of low foaming detergent such as dishwashing machine detergent.
- Switch on whirlpool and run for 10 minutes.
- Drain tub completely before opening the door.
- Fill tub with cold water above jets.
- Switch on whirlpool and run for 15 minutes.
- Drain tub completely.
- Cleaning the Suction Cover. Clean and remove any hair or lint from the suction cover. Monthly, unscrew the suction cover and clean away hair, lint, or debris from the cover and housing, then remount the cover in place. Never operate the unit with the safety suction over off.

Do not use abrasive cleaners as they will scratch and dull the surface of the acrylic.

Plaster can be removed using a wooden stick. DO NOT use a metal scraper, wire brushes or water barrier wallboard or other harsh abrasive tools.

Usually a mild detergent will remove construction debris. More stubborn debris may be removed with denatured alcohol or Clorox Soft Scrub® cleaner.

Light scratches and dulled areas may be restored to original luster by rubbing with an automotive type cleaning compound such as DuPont White Polishing Compound ®.